

Legends



Instruction: additional instruction for software



Note: the problems which may occur during your using of the board and how to resolve and avoid them.



Warning: Harm to human body may occur in the course of using, or damage to the product may occur due to the improper use of the product.

Caution Note



- To avoid electric shock, please do not install the interactive whiteboard at humid locations or locations with smoke!
- After the interactive whiteboard is installed, do not touch its power cable or data cable!
- Keep the interactive whiteboard away from fire, electric shock and direct sunlight!
- After the interactive whiteboard is installed, make sure the whiteboard is firmly fixed!



When the interactive whiteboard is used together with the projector, do not directly watch the light beam sent from the projector.



Important note

- Only erasable interactive whiteboard can be written on with pen of color (including normal whiteboard markers and so on), while for other kinds of boards only using the electronic pens of the interactive whiteboard.
- Please make sure the whiteboard is correctly connected with the computer, and normally powered. It is preferable that the connection cables and power cables be hidden for the wiring so as to prevent the cables from being pulled or drawn.



General note

- Do not scratch the surface or frame of the board with sharp or hard objects.
Environment around: there must be no intense magnetic field. If the wall is made of metal and magnetic materials, there should be 10 meters distance between the Whiteboard and wall.
- When writing on the board with the electronic pen, please keep the pen upright to the board and write lightly.
- If the interactive whiteboard is fixed on the wall surface, it must be vertical to the wall surface.

Contents

LEGENDS	1
CAUTION NOTE	1
CONTENTS	3
INTRODUCTION	4
BRIEF INTRODUCTION	4
FEATURES	4
TOPOLOGICAL DIAGRAM	5
SYSTEM REQUIREMENTS	5
UNPACKING INTERACTIVE WHITEBOARD	6
1、 INTERACTIVE WHITEBOARD	6
2、 STANDARD ACCESSORIES	6
3、 OPTIONAL ACCESSORIES	8
DESCRIPTION OF APPEARANCE	9
INSTALLATION	10
1、 INSTALL INTERACTIVE WHITEBOARD	10
2、 CONNECT INTERACTIVE WHITEBOARD	13
3、 INSTALL BATTERY OF ELECTRONIC PEN	13
4、 EXPRESS INSTALLATION OF WHITEBOARD SOFTWARE	13
5、 STEP-BY-STEP INSTALLATION OF IPBOARD SOFTWARE	16
6、 INSTALL USB — RS232 CONNECTION CABLE DRIVER	17
RUN THE SOFTWARE	20
1. STARTUP DRIVER OF INTERACTIVE WHITEBOARD	20
2. ORIENT THE INTERACTIVE WHITEBOARD	20
3. STARTUP APPLICATION SOFTWARE OF INTERACTIVE WHITEBOARD	21
4. CREATE AN INDIVIDUAL ACCOUNT AND PASSWORD	22
FUNCTION KEYS	24
TROUBLE SHOOTING	25
PERFORMANCE INDEX	27

Introduction

Brief Introduction

As a new generation of digital educational device that will finally substitute traditional blackboards and chalks, Interactive whiteboard is a combination of edge electronic technologies, software technologies and Internet technologies. It is a revolution to the old blackboard-and-chalk pattern that has lasted for hundreds of years.

Interactive whiteboard is a PC-based input equipment, which, when connected with projector and PC, can realized functions such as writing , noting, drawing geometric graphics, editing, printing and storing. Interactive whiteboard will become mainstream equipment for teaching, meeting, remote education and information exchange in the future.

Features

- Applying special techniques as well as advanced and reliable technologies such as electromagnetic induction and digital locating, it can create interactive environment for teaching and demonstration if connected with PC and projector under the support of dedicated software.
- Electronic pen can operate your PC instead of mouse.
- Using electronic pen, you can write, note, erase, copy, clone, replay and save files.
- The upgradeable and expandable software can offer functions such as partially magnifying, partially editing, searchlight, replaying, calligraphy effect, camera, screen and customized template.
- It also features high tracking accuracy, quick response and sensitive operation. The advanced processing algorithm adopted in this device results much better response speed and the operation sensitivity compared to pressure sensitive whiteboard and infrared-ultrasonic whiteboard.
- It also boasts of low reflection, high wear-proof, accurate focus, excellent projection effect and suitability for long time watching. The long-life panel can endures. 10 million times of scribing.
- High precision locating: resolution up to 4096×4096 . You can write fine Chinese character, English words, digitals and fine lines on it.
- Adopting independent IP and proprietary production techniques.

Topological Diagram

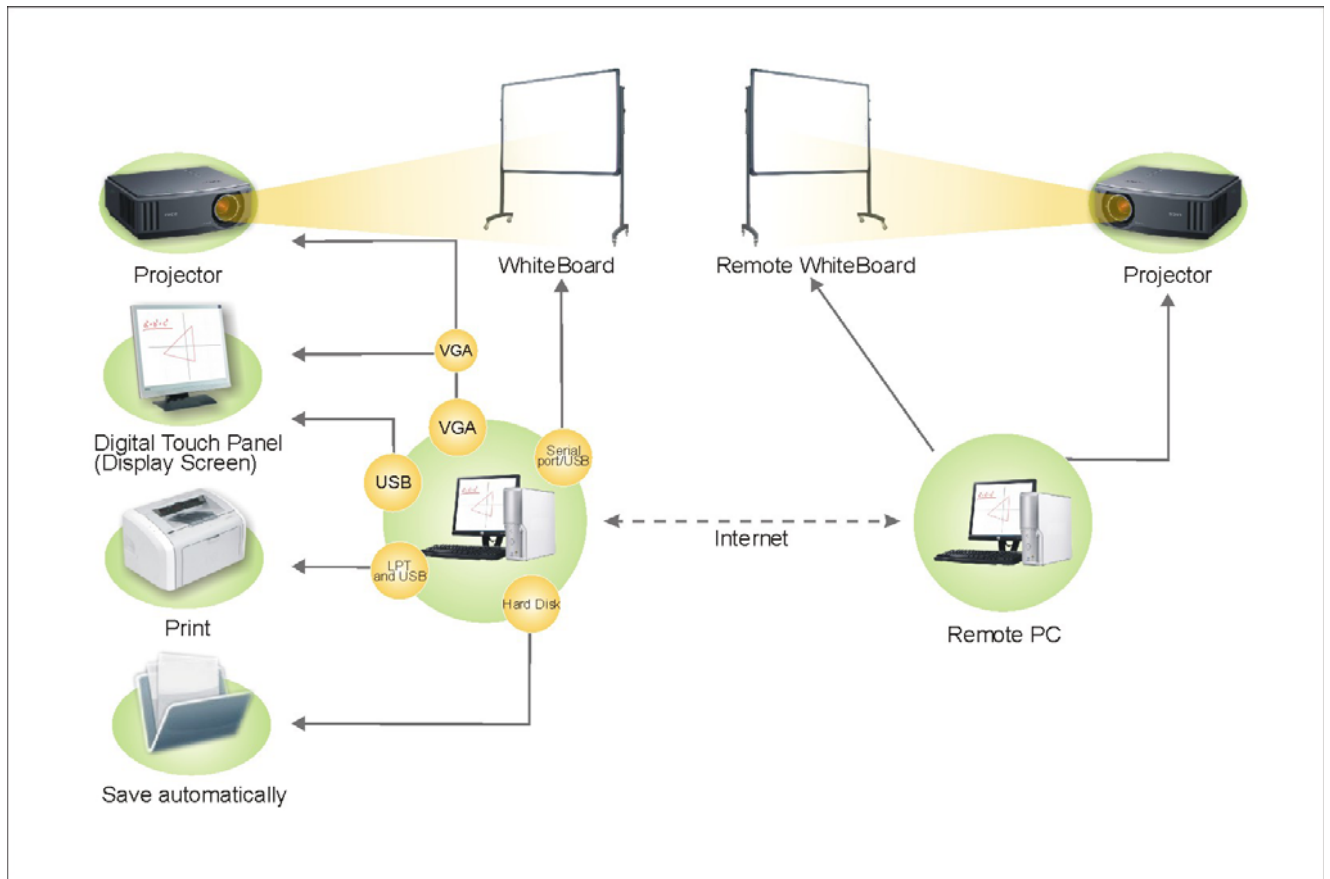

System Requirements

	Minimal configuration	Suggested Configuration
Hardware Configuration	CPU: 1GHz	CPU: 1.7 GHz or more
	RAM: 256 MB	RAM : 512 MB or more
Software configuration	Windows2000, XP、 Vista	Windows2000, XP、 Vista
	Microsoft Internet Explorer 6.0.0	Microsoft Internet Explorer 6.0.0

Unpacking Interactive Whiteboard

A set of Interactive Whiteboard contains the following components:

1、 Interactive Whiteboard

(Color of the product shall in accordance with the product in kind)

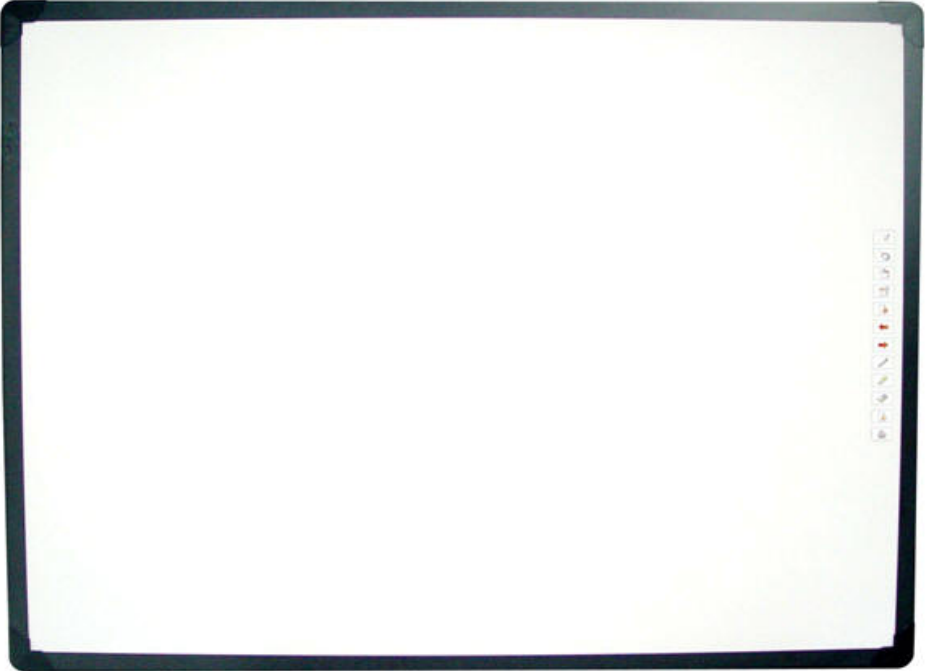

2、 Standard Accessories



Standard Accessories include:

Description	Quantity	Purpose	picture
electronic WHITEBOARD pen	2	The pen specially designed for interactive WHITEBOARD, with Type-7# batteries of 1.5V.	
USB-RS232 connecting cable 10 meters	1	The dedicated cables connecting computer and interactive WHITEBOARD	
《WHITEBOARD Install Software》 Disc	1	drive and application software	
《Interactive WHITEBOARD User Guide》	1	User Guide	
Installation Hanger (Top)	1	For wall mounted installation	
Installation Hanger (bottom)	2	For wall mounted installation	
Gasket	2	For balancing the interactive whiteboard while wall mounted.	

3、 Optional Accessories

If the interactive WHITEBOARD is not installed on wall, you may choose to install it by mobile floor stand.

A mobile floor stand includes side beam, crossbeam, and screw etc. See the following figure (lower and left).



(Color of the product shall in accordance with the product in kind)

Description of Appearance

- Appearance of WHITEBOARD:

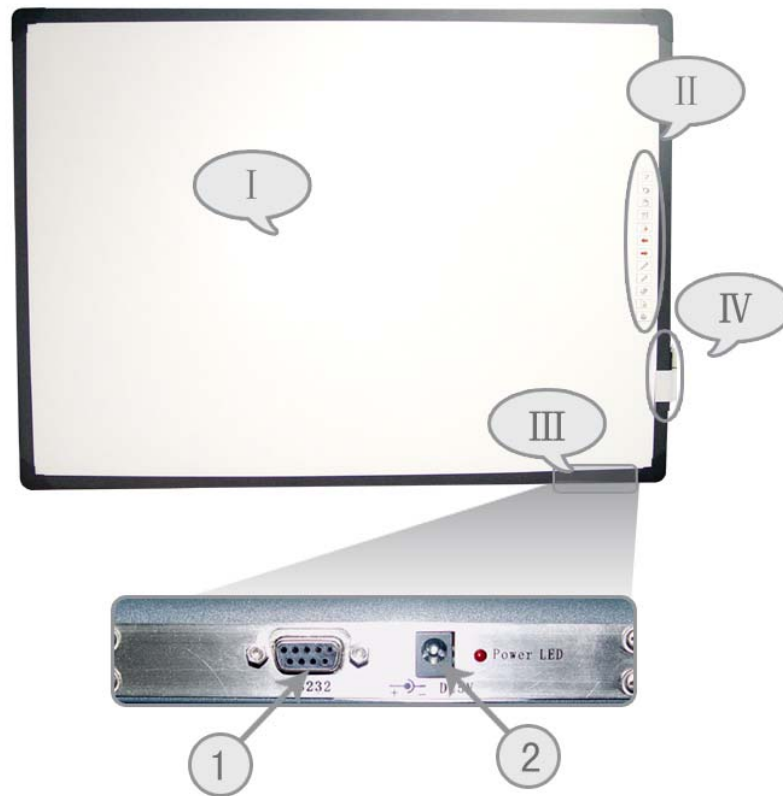

(Color of the product shall in accordance with the product in kind)

I Writing Area;	①Serial port;②Power Socket
II Function keys;	
Interface Board;	
IV Pen Container	

Installation

1、 Install Interactive Whiteboard

- Hanging type
- 1) Select proper wall surface and fix hanging parts on wall surface according to size of interactive WHITEBOARD.
 - 2) then hang the interactive WHITEBOARD onto the hanging parts. The walls must be straight edge.
Fix the hangers onto the wall according to the measurements provided as follows:

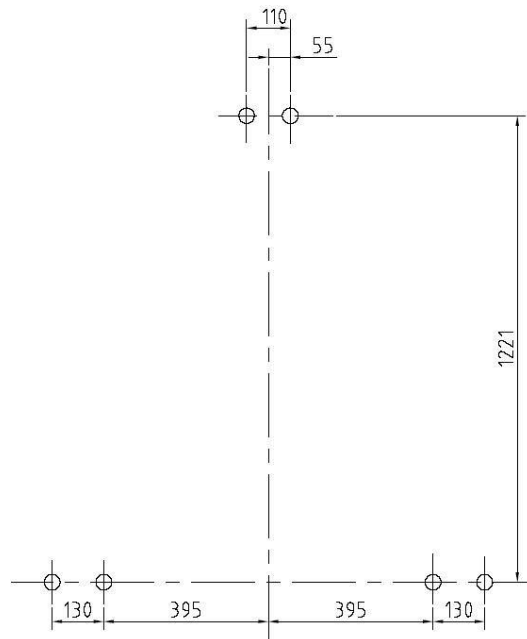

(85-inch size map of installed WHITEBOARD)

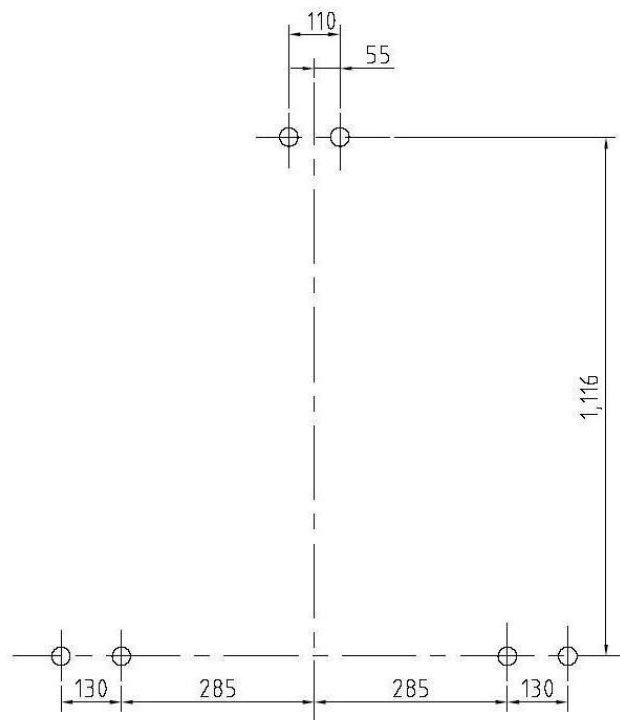

(81-inch size map of installed WHITEBOARD)

3) Hitch the interactive whiteboard to the fixed hangers.

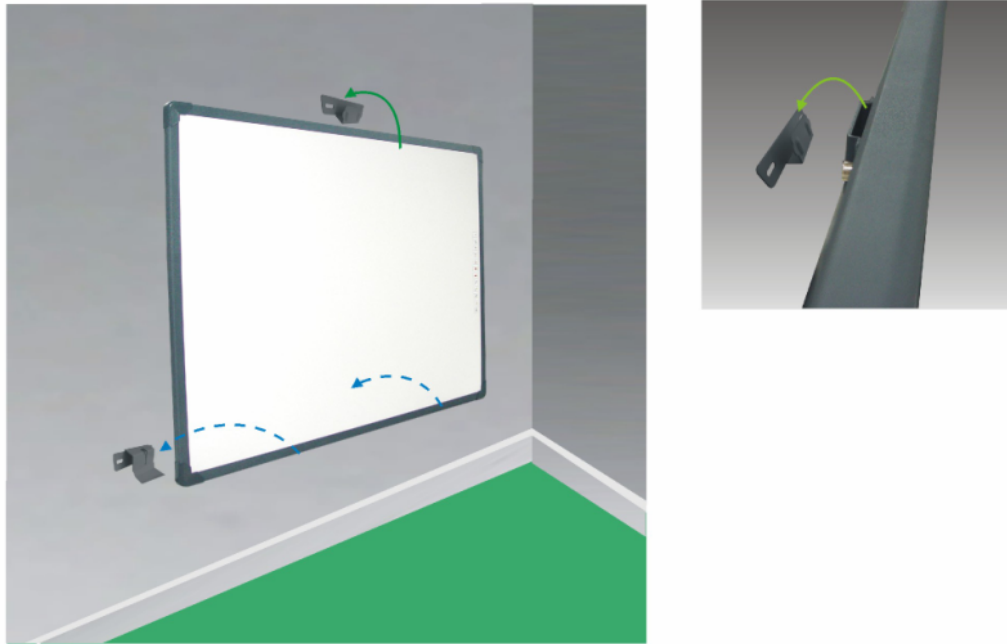

Note: Stick gasket to the back of the interactive whiteboard, please refer to figure below.

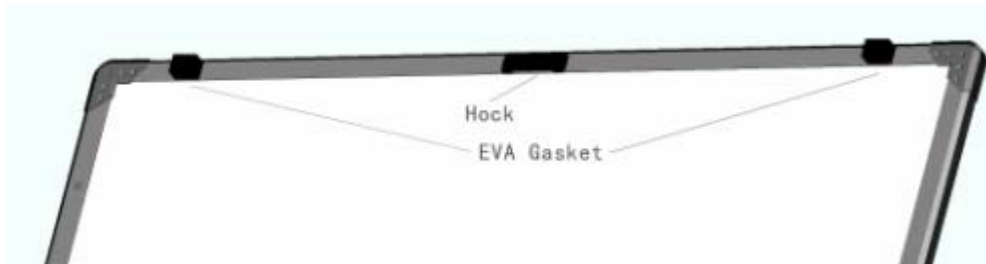

Accessory which install in the back of WHITEBOARD

- Floor stand type installation (floor stands are optional)

Assembly the floor stand according to Floor Stand Installation Diagram, then

Step 1: Beam

Step2: Side Beam

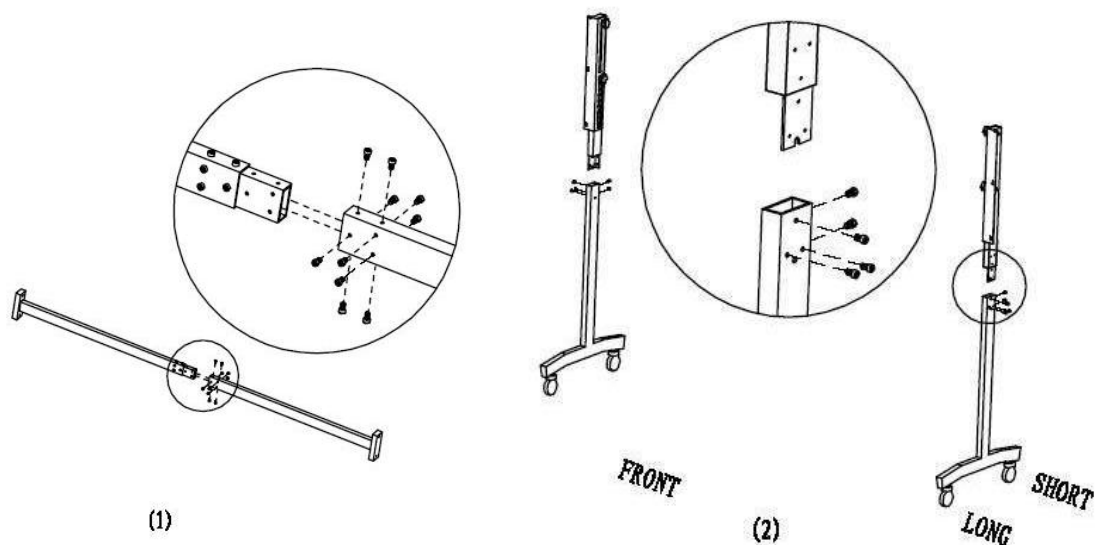

Step 3: Connecting Beam with Side Beam;

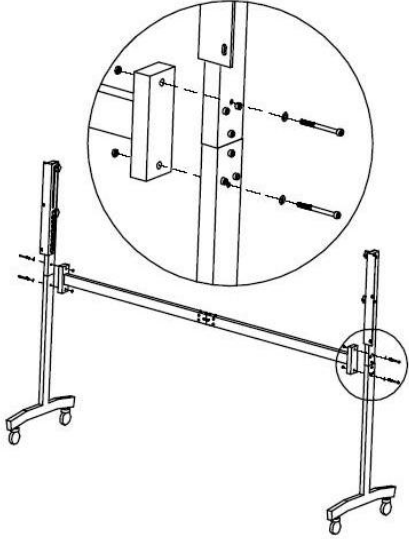

(3)

Step 4: Hitch Board to the Stand

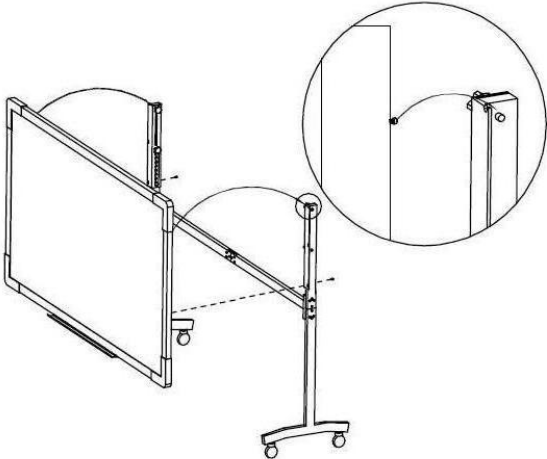

(4)

Step 5: Adjust the Board height;

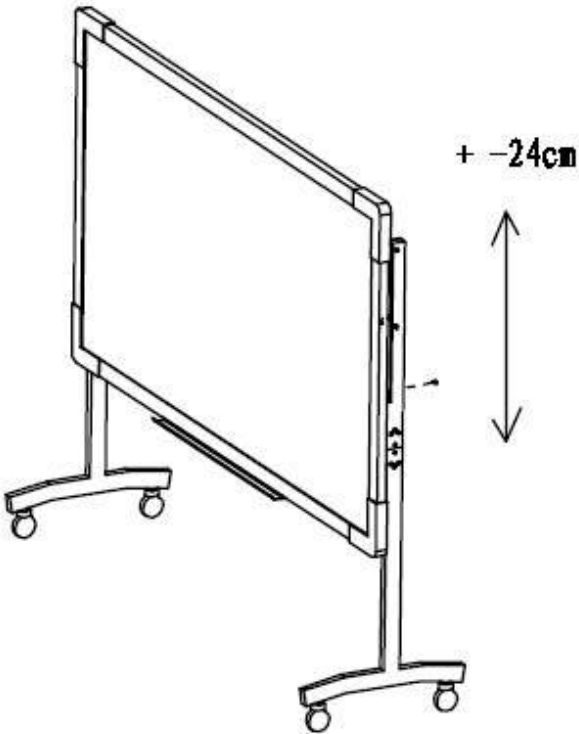

(5)

2、 Connect Interactive Whiteboard

- Connect it to USB port of PC , USB supply DC Power



- 1) Fix interactive whiteboard.
- 2) Connect interactive whiteboard to PC using gorge line.



Interactive whiteboard and PC should be power off when processing all connections!!!

3、 Install Battery of Electronic Pen

Turn the rear cap of the electronic pen counter-clockwise to open it, load one 7# 1.5V battery according to the following figure, then tighten the rear cap clockwise.



4、 Express Installation of WHITEBOARD Software

This installation option is recommended for first time installation of the software.

- 4.1) Insert 《WHITEBOARD Software》 disc;



AutoRun.exe
SetupWizard Micr...

4.2) Click program logo:

4.3) Proceed to Installation Guide window.



4.4) Click **Install All** to install driver for Interactive IPBOARD;

4.5) Choose the language that needed to be installed.

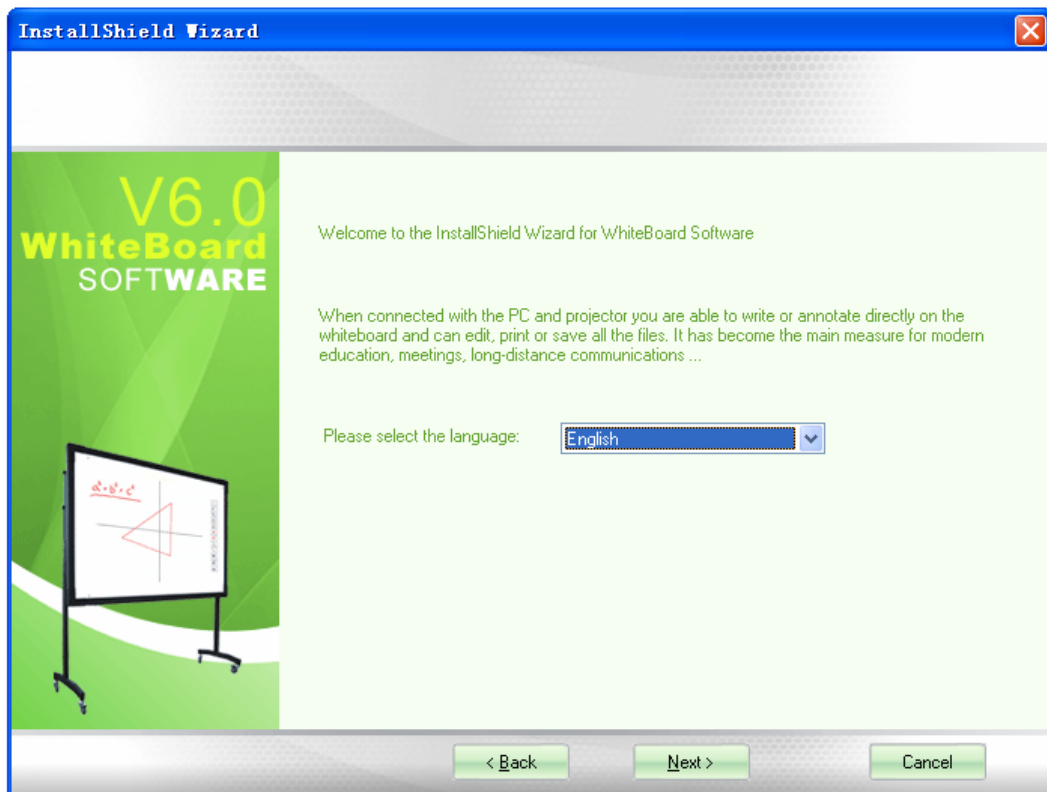

4.6) Select the path for installation.

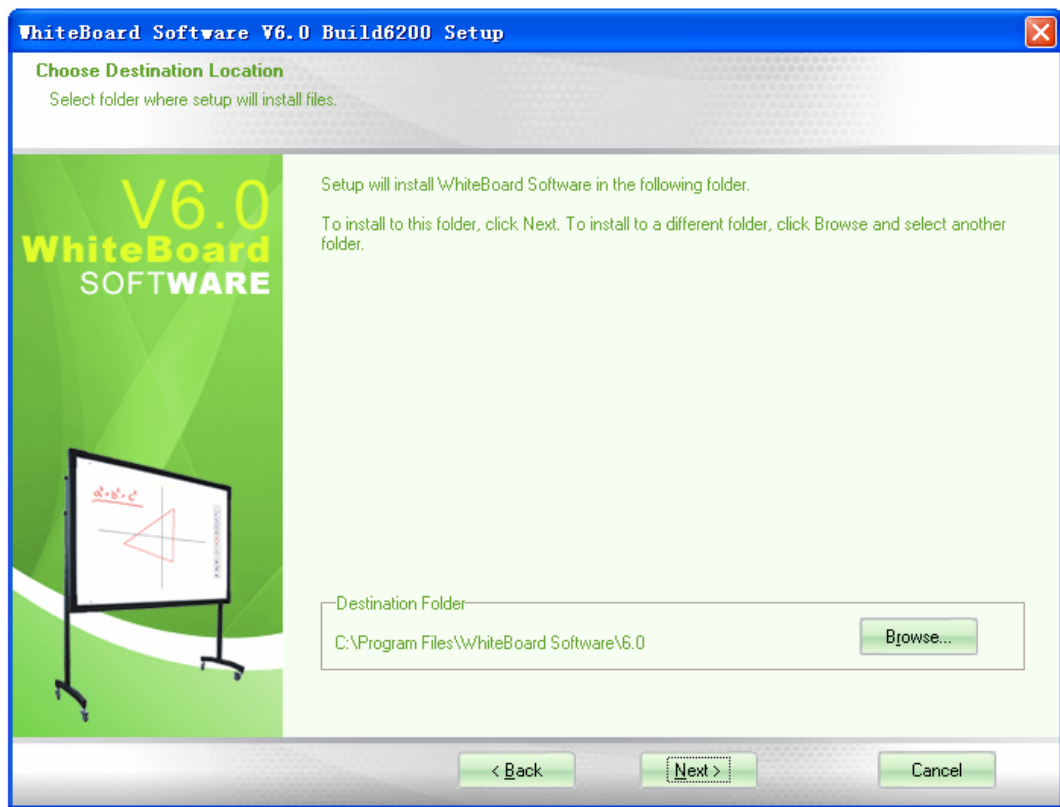

4.7) After the software installation is completed the system will install the USB driver. If the USB cable provided with the IPBOARD is white, click “Yes” to complete the installation of the USB driver. If the USB cable is black, click “No” and proceed to **Install Step By Step** → **Install USB Driver** → **Install Silicon Driver** to install the driver.

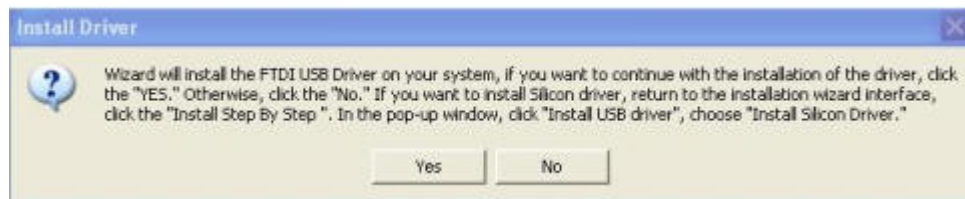

4.8) After the driver installation is completed connect the USB cable to the PC to complete the whole process.

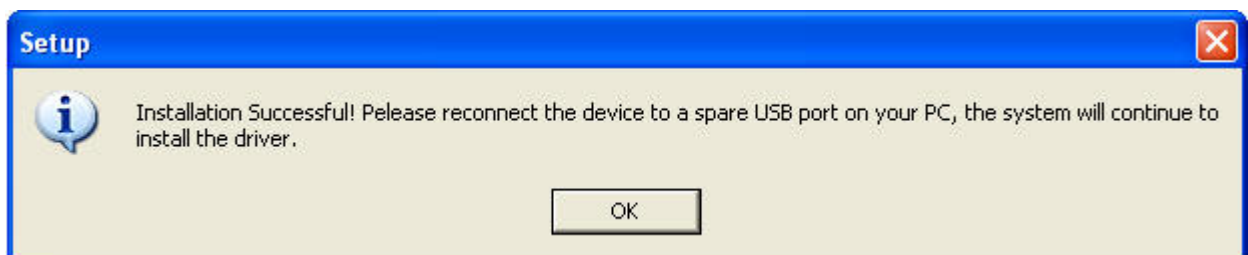

4.9) Complete installation.

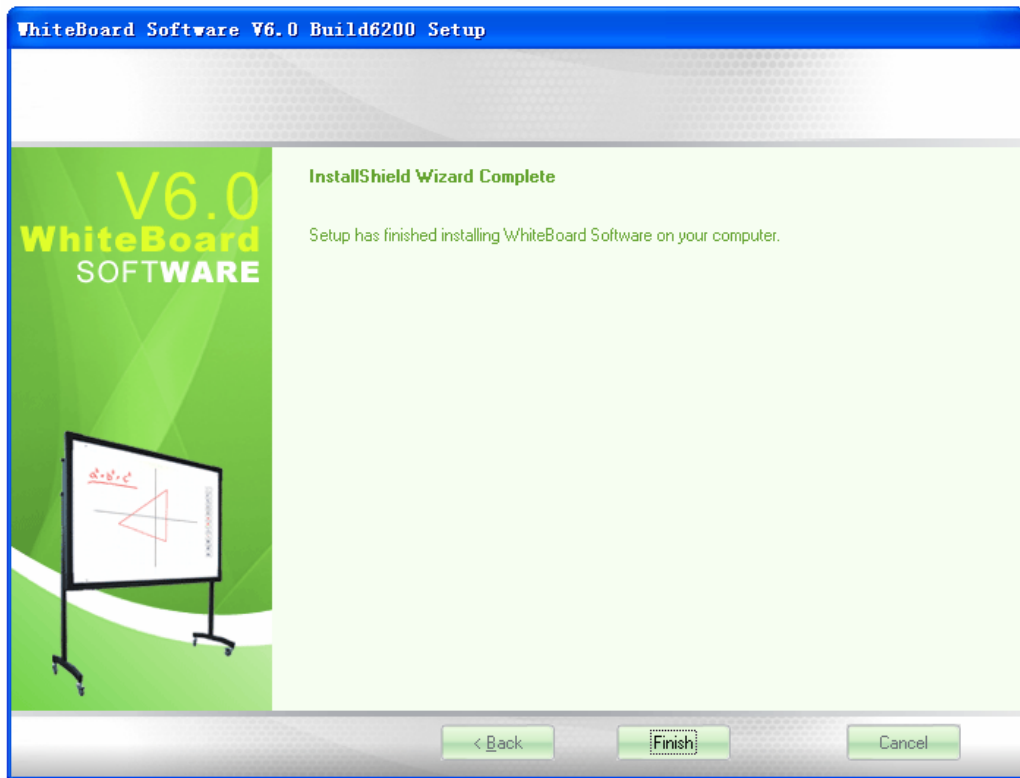

5、 Step-by-step Installation of IPBOARD Software

This installation option is recommended when upgrading IPBOARD software or replacing the USB cable.

5.1) Follow 4.1) — 4.3) to enter installation guide window.

5.2) Click **Install Step By Step** to install IPBOARD driver, IPBOARD software and USB cable by following the step-by-step guide.

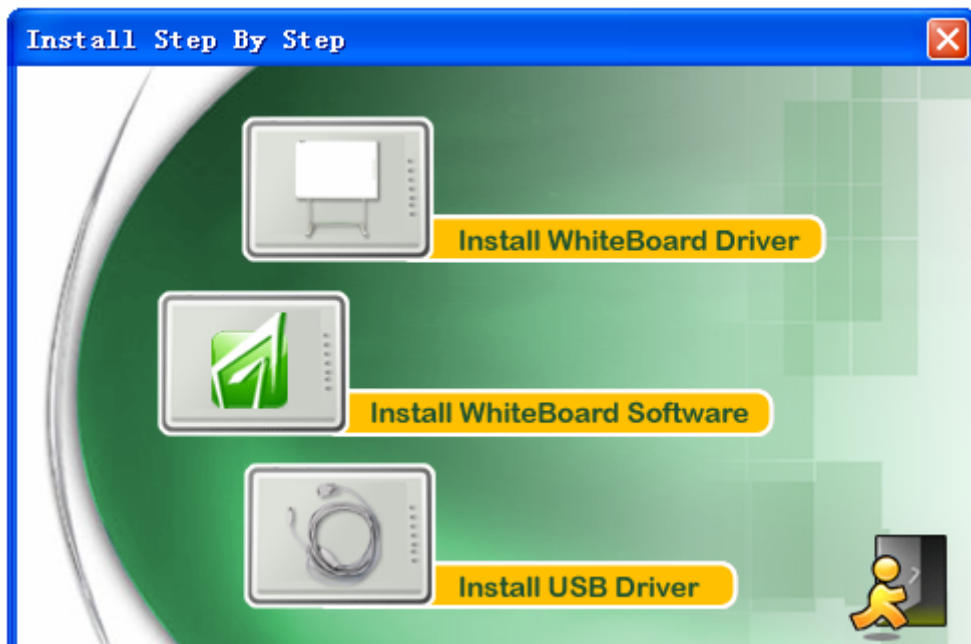

5.3) Install IPBOARD Drive



5.3.1) Click  to install driver for Interactive Whiteboard;

5.3.2) Choose the language that needed to be installed.

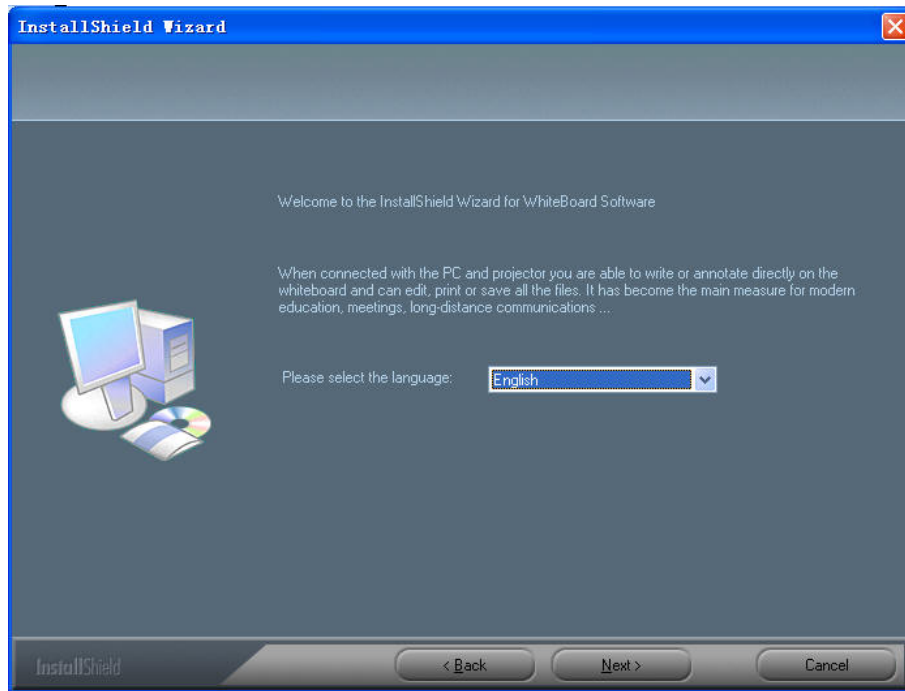

5.3.3) Select the path for installation.

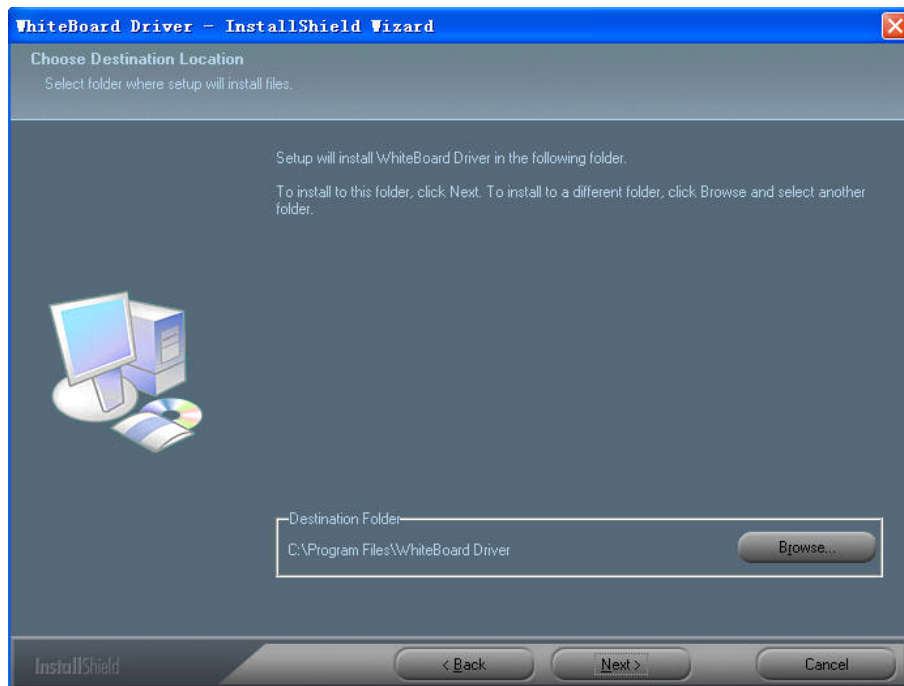

5.3.4) Complete installation.

5.4) Install IPBOARD Software



Click and follow 4.5) — 4.8) to complete the installation.

6、 Install USB—RS232 connection cable Driver

There is no need to repeat this step when using Express Installation. This step is only required when using

 **If USB-RS232 connection cable is used, the corresponding driver must be installed.**

Click   to install the driver for USB-RS232 cable.

6.1) Installation of white USB-RS232 cable

If the USB cable provided with the IPBOARD is white, click  to install the driver.



After installing correctly “My Computer” → “Properties” “Hardware” → “Device Manager” “Port” are shown as the device “USB Serial Port”



 **After installation of USB-RS232 cable is completed, plug-in the USB cable, and to check the COM number of the USB Serial Port in “My Computer”→ “Properties” → “Hardware” →“Device Manager” → “Port” and to make sure that the COM number is less then 10 and the baud rate is 19200.**

6.2) Installation of black USB-RS232 cable

If the cable provided with the IPBOARD is black, click  to install the driver.

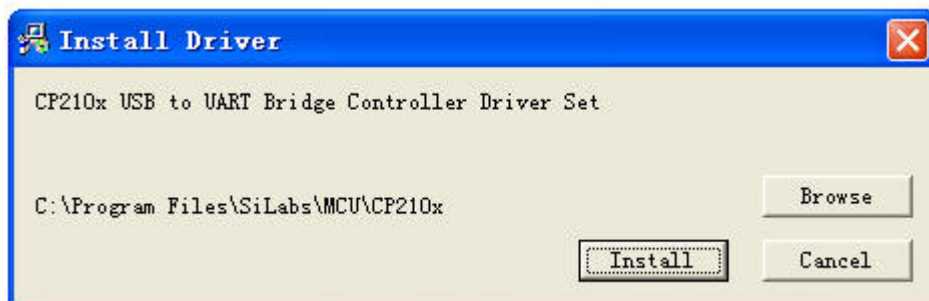

click  and begin to install USB-RS232 cable until complete installation

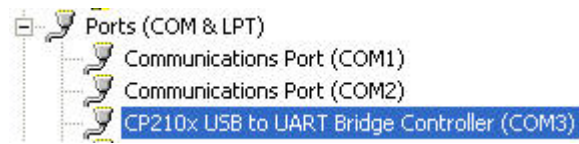

After installing correctly in “My Computer” → “Properties” →“Hardware” →“Device Manager” “Port” can see the device “CP210X USB to UART Bridge Controller



After installation of USB-RS232 cable is completed, plug-in the USB cable, and to check the COM number of the CP210X USB to UART Bridge Controller in “My Computer”→“Properties”→“Hardware”→ “Device Manager”→“Port” and to make sure that the COM number is less than 10 and the baud rate is 19200.

Run the Software

1. Startup driver of interactive whiteboard

Click "Start" → "All programs" →  WhiteBoard Software "→"  WhiteBoard Driver "

and start whiteboard driver. It will show a tray icon of communication module  in status bar lower-right corner of desktop.



If it shows "Communication with board failed", please make sure that the connecting cable and Interactive Whiteboard is correctly connected and the driver for the USB cable has been correctly installed. Then please click the Whiteboard Driver icon in the tray and select "Reconnect Interactive Whiteboard" in the pop-up manual.

2. Orient the interactive whiteboard

- 1) Click tray icon  of interactive whiteboard by left key of mouse, select "**Orientation**" on the popup menu to enter locating interface of whiteboard, and select one locating mode required, as shown below.

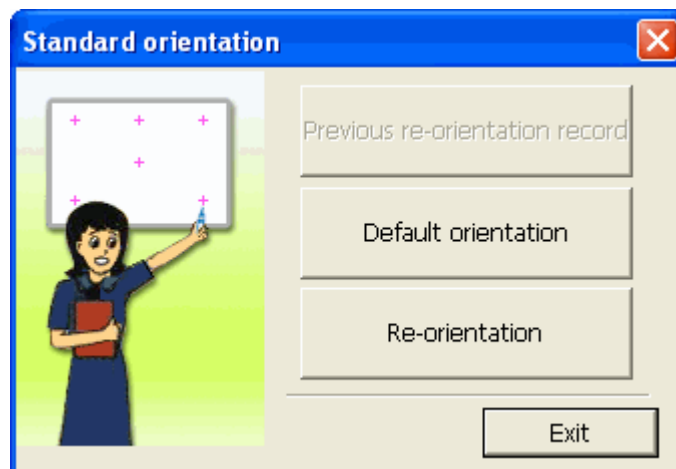

- 2) Left click "**Re-orientation**", it will popup window of Orientation, click central position of the flashing sign "+" using electronic pen. Click it following prompt (there are six orientation points in all, left up, right up, right down, left down, top up and middle).as shown below:

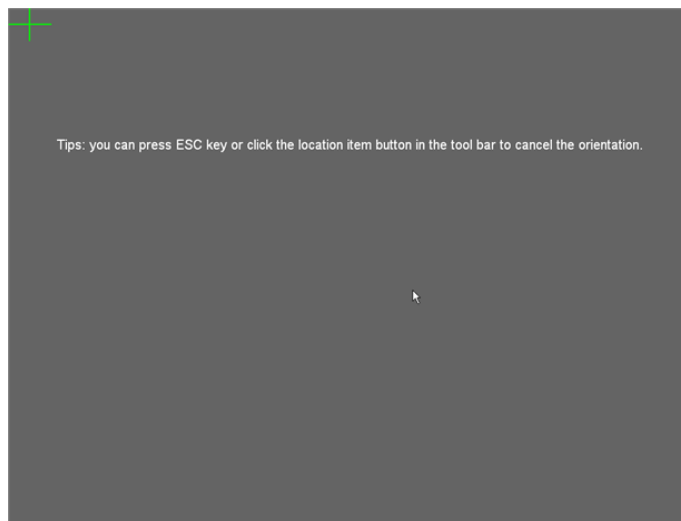

	<ul style="list-style-type: none">◆ Please select "Re-orientation" when the first time to install interactive whiteboard or position of hardware unit (projector and interactive whiteboard) has been changed.◆ You can have a fast orientation by selecting "Previous re-orientation record" so as to ensure accuracy, if there are no hardware changes since last time.◆ When no need for accurate orientation, you can select " default orientation".
--	---

3. Startup application software of interactive whiteboard

1) Click **"Start"** → **"All programs"** →  **WhiteBoard Software** →

 **WhiteBoard Software**, and startup application program, then it will popup a Logon window as shown below



2) Users can use default user account or their individual accounts to log-in Whiteboard Software. Users are able to create customized toolbar, resources and templates if they are using their individual accounts.

	<p>Ensure the connection between interactive whiteboard and PC is good and driver of interactive whiteboard is running before starting up application software. if not, application program will not startup normally .</p>
--	---

4、 Create an individual account and password

1) Click “Start” → “All Programs” → “ WhiteBoard Software” →

 User Manager and will pop-up the following window:

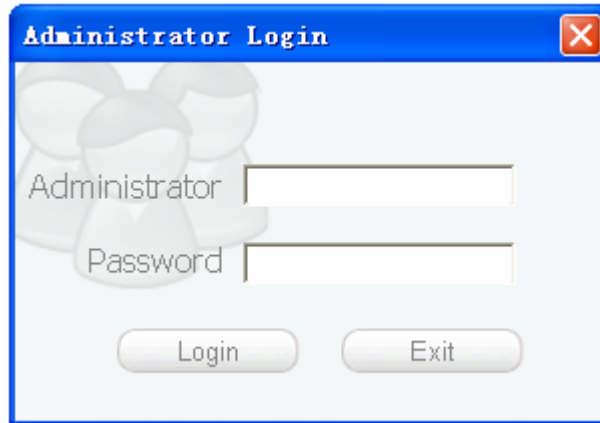

Key-in the administrator account to enter the software. Default administrator account is: **Administrator**,
Password: 123.

2) Enter the User Manager window

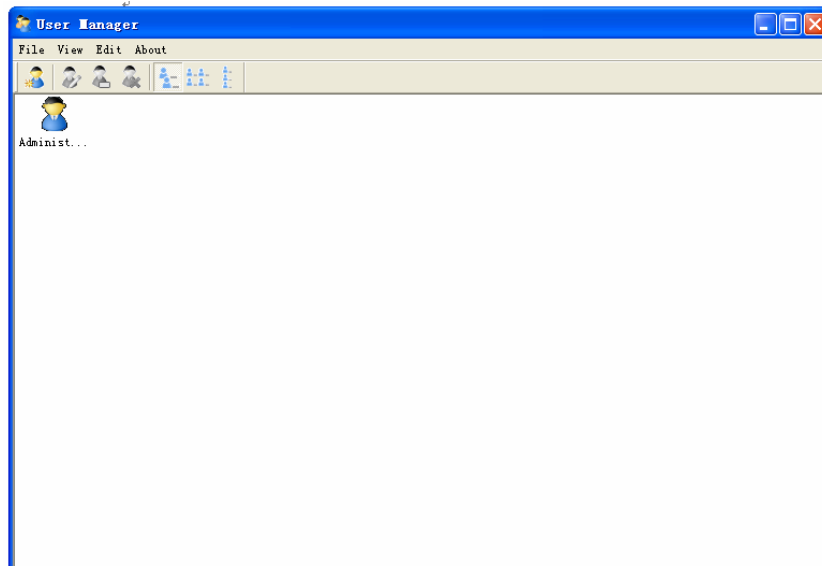

3) Select “Edit” → “New User” to create an individual account.

4) Key-in the user name and password and select Create.

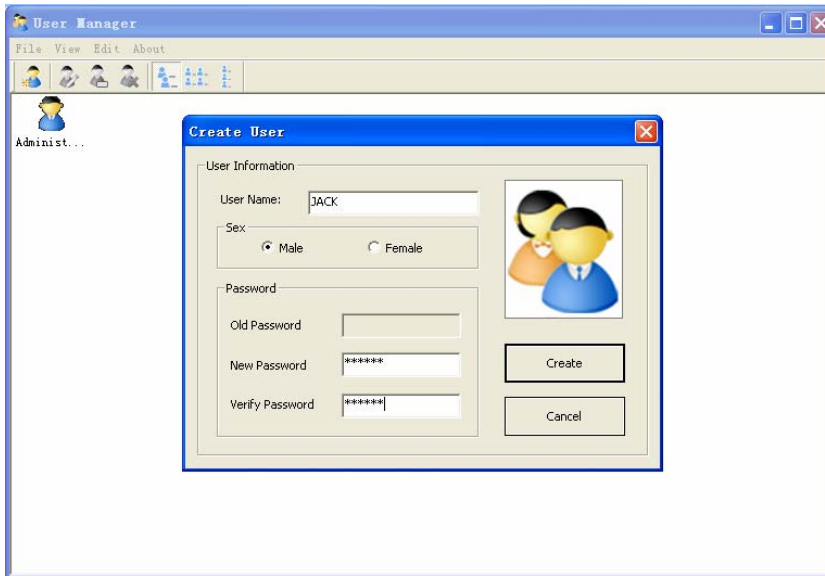

5) The new user will be displayed in the window after the process is completed.:

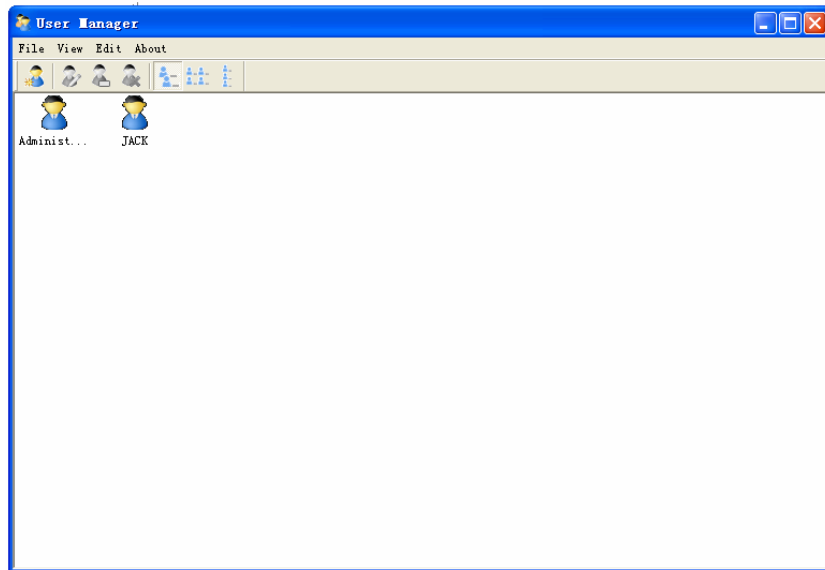

Function Keys

Function keys	Definition	Control Mode	Window Mode	Annotation Mode
	Orientation	Orientation	Orientation	Orientation
	Control Mode	No Effect	Switch to control mode	Switch to control mode
	Annotation Mode	Switch to annotation mode	Switch to annotation mode	No Effect
	Window Mode	No Effect	Head Page	Head Page
	Create a blank page	Create a blank page	Create a blank page	Create a blank page
	Page Up	No Effect	Page Up	Page Up
	Page Down	No Effect	Page Down	Page Down
	Normal Pen	Switch to annotation mode and use Normal Pen	Normal Pen	Normal Pen
	Transparent Pen	Switch to annotation mode and use Transparent Pen	Transparent Pen	Transparent Pen
	Eraser	Eraser	Eraser	Eraser
	Replay	Replay Pages	Replay Pages	Replay Pages
	Print	Print	Print	Print

Trouble Shooting

1. If it shows “Failed to verify the WHITEBOARD, the program can't run further!” please check whether there is a good connection between WHITEBOARD and PC.”

- Please check whether having used special-purpose gorge line of WHITEBOARD, and whether there is a good connection for gorge line.
- When connection is made through the USB2.0 to RS232C cable, check whether it is correctly connected with special-purpose gorge line.
- Check whether the WHITEBOARD is power-on (It is normal only when the red indicator lamp on plug socket of power lightening).
- Check whether serial ports from COM1 to COM10 have been occupied, and you must select one serial port from COM1 to COM10 for WHITEBOARD.
- Check whether driver of WHITEBOARD has been setup correctly.

2. When startup software, it shows “Error happen when Loading XML File”.

Check the version of Internet Explorer, upgrade IE to version 6.0 when it is 5.0 or lower.

3. Only part of WHITEBOARD can be written on.

Check whether orientation of WHITEBOARD is correct.

4. Some orientation points can not found when orienting the WHITEBOARD.

Check whether lateral deviation and vertical offset of projector are correct. Ensure all content on PC screen can be projected wholly to WHITEBOARD.

5. Electronic pen cannot write normally.

- Check current working mode of software. Writing is effective only under Draw Mode or Annotation Mode, and not effective under Control Mode.
- Do not press button on electronic pen when writing.
- Please keep the neb of electronic pen is vertical to panel of WHITEBOARD.
- You should not press the electronic pen tightly.
- Check whether the battery is full of power, if not, replace new ones.

6. How to exit from software of WHITEBOARD?

- Click icon button of "Pop Menu" on Floating Tool Bar, click "Exit" in the pop up menu.
- Or click "File"(on main menu)→“Exit”.

7. Why image Projected is shape of trapezium? why to adjust it, and how to adjust it?

- It may be that projector is not level (like, the front is higher than the back or the back is higher than the front),so a trapezium appears.
- The image will be in distortion when a trapezium appears, so you must adjust it to normal condition.
- Generally, it can be adjusted by using a remote manipulator or to adjust height of projector. For details, please refer to user's manual of projector.



Trapezia



Rectangle

8. What type of projector is needed to match with the interactive WHITEBOARD?

The projector shall satisfy with three items as below.

- 1) Front projector
- 2) Support resolution of PC
- 3) Least luminous power shall be more than 500 Lumina, for detail requirements, please refer to size of room.

9. How to do it when serial port is occupied.

Both table model and notebook PC allow to add some new serial port, there are two ways to select

- Install a serial port card on PC (note: generally, PCMCIA serial port card for notebook PC)
- Using "USB2.0 to RS232C+ special designed gorge line" to connect WHITEBOARD with PC together.

10. Can 25-pin serial port replace 9-pin serial port?

Yes, but only you have installed an adapter from 25 to 9 pins on PC.

11. What to do when having used an un-erasable and unctuousity color pen to write on WHITEBOARD.

Never use unctuousity color pen writing on WHITEBOARD! Once you have done it, clean it lightly using absorbent cotton dipped with alcohol.

12. How to clean the panel of WHITEBOARD?

Clean the panel lightly using a piece of cleanly damping cloth.

Attention: you have to wring out the damping cloth, there are must not be floating water, and you must prevent some water infiltrating into internal side of WHITEBOARD.

Performance index

Hardware Platform	Common PC, notebook PC
Operation System	Windows 2000/XP/Vista
Transmission Interface	RS-232C/USB / Wireless Module
Resolution	8192×8192
Data-signaling rate	19200Baud Rate
Operating Principle	Wireless electromagnetic induction
Operate Mode	Control Mode/ Window Mode / Annotation Mode./Full-screen Mode
USB Power Supply	DC 5V 100mA Or Powered by external 5V adapter
Service life of battery of electronic pen	Different service life for different battery, common alkaline battery can endures three months
Working Temperature	-20℃ ~ +55℃
Power capability	< 2W